



TRUE FOOD SERVICE EQUIPMENT, INC.

2001 East Terra Lane • O'Fallon, Missouri 63366-4434 • (636)240-2400
 Fax (636)272-2408 • Toll Free (800)325-6152 • Intl Fax# (001)636-272-7546
 Parts Dept. (800)424-TRUE • Parts Dept. Fax# (636)272-9471 • www.truemfg.com

Project Name: _____

Location: _____

Item #: _____ Qty: _____

Model #: _____

A/A #

S/S #

Model:
G4SM-23RGS~TSL01

Glass Four Sided Merchandiser:
Swing Door Rotating Glass Shelf Refrigerator~True Standard Look Version 01



Shown with optional Dessert Sign.

G4SM-23RGS~TSL01

- ▶ The world's #1 manufacturer of glass door merchandisers.
- ▶ True's commitment to using the highest quality materials and oversized refrigeration systems provides the user with colder product temperatures, and lower utility costs in a unique merchandiser that creates a dynamic 360° product display.
- ▶ Exterior - attractive, high luster bronze powder coated finish.
- ▶ Oversized, factory balanced, refrigeration system holds 33°F to 38°F (.5°C to 3.3°C).
- ▶ Interior - attractive, NSF approved, white aluminum interior liner with 300 series stainless steel floor.
- ▶ Door is self closing with a positive seal, torsion type closure system.
- ▶ "Low-E", double pane thermal glass in door assembly, sides and rear. The latest in energy efficient technology.
- ▶ LED interior lighting provides more even lighting throughout the cabinet. Safety shielded.
- ▶ Entire cabinet structure is foamed-in-place using Ecomate. A high density, polyurethane insulation that has zero ozone depletion potential (ODP) and zero global warming potential (GWP).

Bottom mounted units feature

- ▶ "No stoop" lower shelf to maximize product visibility.
- ▶ Storage on top of cabinet.
- ▶ Easily accessible condenser coil for cleaning.

ROUGH-IN DATA

Specifications subject to change without notice.
 Chart dimensions rounded up to the nearest 1/8" (millimeters rounded up to next whole number).

Model	Doors	Shelves	Cabinet Dimensions (inches) (mm)			HP	Voltage	Amps	NEMA Config.	Cord Length (total ft.) (total m)	Crated Weight (lbs.) (kg)
			W	D†	H						
G4SM-23RGS~TSL01	1	6	27½ 699	30⅞ 766	78⅞ 1998	⅓ N/A	115/60/1	5.8 N/A	5-15P	9 2.74	TBD TBD

† Depth does not include 1½" (42 mm) for door handle.

	<p>APPROVALS:</p>	<p>AVAILABLE AT:</p>
12/17	Printed in U.S.A.	

Model:
G4SM-23RGS~TSL01

Glass Four Sided Merchandiser:
Swing Door Rotating Glass Shelf
Refrigerator~True Standard Look Version 01



STANDARD FEATURES

DESIGN

- True's commitment to using the highest quality materials and oversized refrigeration systems provides the user with colder product temperatures, and lower utility costs in a stylish merchandiser that creates a dynamic 360° product display.
- Attention commanding-revolving glass shelves provide high visibility difference for high profit dessert items.

REFRIGERATION SYSTEM

- Factory engineered, self-contained, capillary tube system using environmentally friendly (CFC free) 134A refrigerant.
- Extra large evaporator coil balanced with higher horsepower compressor and large condenser; maintains cabinet temperatures of 33°F to 38°F (.5°C to 3.3°C).
- Sealed, self-lubricating evaporator fan motors and larger fan blades give True merchandisers a more efficient low velocity, high volume airflow design. This unique design ensures more consistent, colder holding temperatures and faster recovery in high use situations.
- Bottom mounted condensing unit positioned for easy maintenance; "no stoop" lower shelf maximizes visibility by raising merchandised product to higher level.

CABINET CONSTRUCTION

- Exterior - attractive, high-luster bronze powder coated finish. Bronze finish is not a solid color and designed with slight variations throughout for high end appearance.

- Low-E, double pane thermal insulated glass sides and door assembly. The latest in energy efficient technology.
- Interior - attractive, NSF approved, white aluminum interior liner with stainless steel floor.
- Insulation - entire cabinet structure is foamed-in-place using a high density, polyurethane insulation that has zero ozone depletion potential (ODP) and zero global warming potential (GWP).
- Welded, heavy duty steel frame rail, black powder coated for corrosion protection.
- Frame rail fitted with leg levelers.
- Illuminated exterior front sign panel. Variety of sign options available.

DOOR

- "Low-E", double pane thermal insulated glass door assembly with extruded aluminum frame. The latest in energy efficient technology.
- Door fitted with 12" (305 mm) long extruded handle.
- Self closing door. Positive seal, torsion type closure system.
- Magnetic door gasket of one piece construction, removable without tools for ease of cleaning.

SHELVING

- 360° revolving shelf system with 6 non-adjustable 21 5/8" (220 mm) diameter round shelves; 5 tempered glass and 1 tempered mirrored glass. Mirrored shelf designed to be used on bottom level.

LIGHTING

- LED interior lighting provides more even lighting throughout the cabinet. Safety shielded.

MODEL FEATURES

- Evaporator is epoxy coated to eliminate the potential of corrosion.
- See our website www.truemfg.com for latest color and sign offerings.
- NSF/ANSI Standard 7 compliant for open food product.

ELECTRICAL

- Unit completely pre-wired at factory and ready for final connection to a 115/60/1 phase, 15 amp dedicated outlet. Cord and plug set included.



115/60/1
NEMA-5-15R

OPTIONAL FEATURES/ACCESSORIES

Upcharge and lead times may apply.

- Black exterior.
- White exterior.
- Black aluminum interior liner.
- 6" (153 mm) standard legs.
- 6" (153 mm) seismic/flanged legs.
- 2 1/2" (64 mm) diameter castors.
- 4" (102 mm) diameter castors.
- Red wine thermostat.
- Chocolate thermostat.
- White wine thermostat.

PLAN VIEW

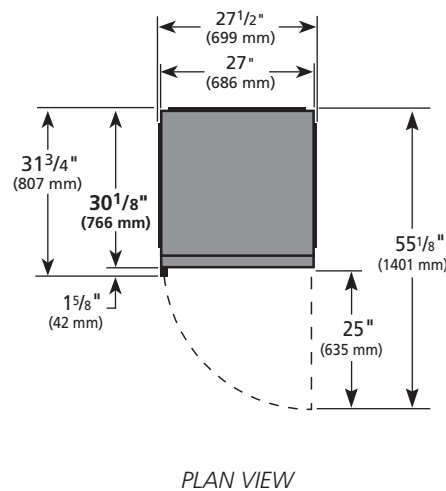
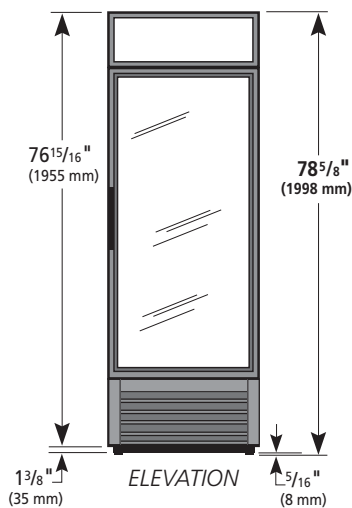

WARRANTY*
Three year warranty on all parts and labor and an additional 2 year warranty on compressor. (U.S.A. only)

METRIC DIMENSIONS ROUNDED UP TO THE NEAREST WHOLE MILLIMETER
SPECIFICATIONS SUBJECT TO CHANGE WITHOUT NOTICE



Model	Elevation	Right	Plan	3D	Back
G4SM-23RGS~TSL01					

TRUE FOOD SERVICE EQUIPMENT