



TRUE MANUFACTURING CO., INC.
U.S.A. FOODSERVICE DIVISION

2001 East Terra Lane • O'Fallon, Missouri 63366-4434 • (636)240-2400
Fax (636)272-2408 • Toll Free (800)325-6152 • Intl Fax# (001)636-272-7546
Parts Dept. (800)424-TRUE • Parts Dept. Fax# (636)272-9471 • www.truemfg.com

Project Name: _____

Location: _____

Item #: _____ Qty: _____

Model #: _____

A/A #

SIS #

Model:
TD-50-18-HC

Underbar Refrigeration:

Solid Slide Lid Deep Well Horizontal Bottle Cooler with Hydrocarbon Refrigerant



TD-50-18-HC

- ▶ True's horizontal bottle coolers are designed with enduring quality and value. Our commitment to using the highest quality materials and oversized refrigeration assures colder product temperatures and years of trouble free service.
- ▶ Factory engineered, self-contained, capillary tube system using environmentally friendly R290 hydro carbon refrigerant that has zero (0) ozone depletion potential (ODP), & three (3) global warming potential (GWP).
- ▶ High capacity, factory balanced refrigeration system that maintains cabinet temperatures of 33°F to 38°F (.5°C to 3.3°C) for the best in food preservation.
- ▶ Forced-air cooling. Positively guided airflow cools bottles on top first. Evaporator coil virtually runs length of cooler for balanced temperatures throughout the cabinet.
- ▶ Exterior - stainless steel countertop and lids, black powder coated cold rolled steal front, sides, and back.
- ▶ Interior - long lasting, heavy duty galvanized steel. Complies with NSF/ ANSI Standard 7 for packaged and bottled product.
- ▶ Evaporator is epoxy coated to eliminate the potential of corrosion.
- ▶ Heavy duty, 10 mil thick pure grade PVC coated adjustable bin dividers.
- ▶ Entire cabinet structure is foamed-in-place using a high density, polyurethane insulation that has zero ozone depletion potential (ODP) and zero global warming potential (GWP).

ROUGH-IN DATA

Chart dimensions rounded up to the nearest 1/8" (millimeters rounded up to next whole number).

Specifications subject to change without notice.

Model	Lids	Capacity		Cabinet Dimensions (inches) (mm)			HP	Voltage	Amps	NEMA Config.	Cord Length (total ft.) (total m)	Crated Weight (lbs.) (kg)
		12 oz. Btls.	12 oz. Cans	W	D†	H						
TD-50-18-HC	2	16.5 Cases	24 Cases	49½ 1255	26⅞ 683	33½ 850	½ N/A	115/60/1	1.9 N/A	5-15P	7 2.13	275 125

† Depth does not include 1" (26 mm) for rear bumpers.

10/18 Printed in U.S.A.

APPROVALS:

AVAILABLE AT:

Model:
TD-50-18-HC

Underbar Refrigeration:

Solid Slide Lid Deep Well Horizontal Bottle Cooler with Hydrocarbon Refrigerant

STANDARD FEATURES

DESIGN

- True's refrigerated horizontal bottle coolers are designed with enduring quality and value. Our commitment to using the highest quality materials and oversized refrigeration assures colder product temperatures and years of trouble free service.

REFRIGERATION SYSTEM

- Factory engineered, self-contained, capillary tube system using environmentally friendly R290 hydrocarbon refrigerant that has zero (0) ozone depletion potential (ODP), & three (3) global warming potential (GWP).
- High capacity, factory balanced refrigeration system that maintains cabinet temperatures of 33°F to 38°F (5°C to 3.3°C).
- State of the art, electronically commutated evaporator and condenser fan motors. ECM motors operate at higher peak efficiencies and move a more consistent volume of air which produces less heat, reduces energy consumption and provides greater motor reliability.
- Condensing unit accessed from behind front grill, slides out for easy maintenance.

- Forced-air cooling. Positively guided air flow cools bottles on top first. Evaporator coil virtually runs length of cooler for balanced temperatures throughout the cabinet.

CABINET CONSTRUCTION

- Exterior - Stainless steel countertop and lids, black powder coated cold rolled steel front, sides, and back.
- Interior - long lasting, heavy duty galvanized steel.
- Insulation - entire cabinet structure is foamed-in-place using a high density, polyurethane insulation that has zero ozone depletion potential (ODP) and zero global warming potential (GWP).
- Welded, heavy duty steel frame rail, black powder coated for corrosion protection.
- Bottle cap opener and cap catcher included. Field installed.

BIN DIVIDERS

- Three (3) heavy duty, 10 mil thick pure grade PVC coated adjustable bin dividers to maximize storage.

LIGHTING

- LED interior lighting provides more even lighting throughout the cabinet. Safety shielded.

MODEL FEATURES

- Evaporator is epoxy coated to eliminate the potential of corrosion.
- Barrel locks standard.
- Complies with NSF/ANSI Standard 7 for the storage and/or display of packaged or bottled product.

ELECTRICAL

- Unit completely pre-wired at factory and ready for final connection to a 115/60/1 phase, 15 amp dedicated outlet. Cord and plug set included.



115/60/1
NEMA-5-15R

OPTIONAL FEATURES/ACCESSORIES

Upcharge and lead times may apply.

- 6" (153 mm) standard legs.
- 6" (153 mm) seismic/flanged legs.
- 2 1/2" (64 mm) diameter rail castors.
- 3" (77 mm) diameter rail castors.

PLAN VIEW

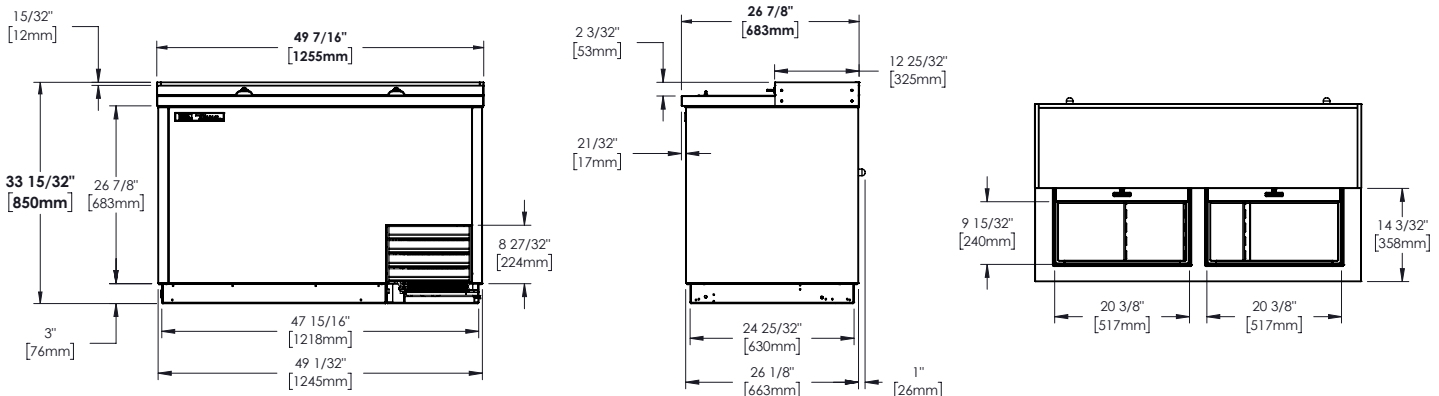

WARRANTY

Three year warranty on all parts and labor and an additional 2 year warranty on compressor. (U.S.A. only)

METRIC DIMENSIONS ROUNDED UP TO THE NEAREST WHOLE MILLIMETER

SPECIFICATIONS SUBJECT TO CHANGE WITHOUT NOTICE



Model	Elevation	Right	Plan	3D	Back
TD-50-18-HC					

TRUE MANUFACTURING CO., INC.

2001 East Terra Lane • O'Fallon, Missouri 63366-4434 • (636)240-2400 • Fax (636)272-2408 • Toll Free (800)325-6152 • Intl. Fax# (001)636-272-7546 • www.truefmfg.com