



Master Series Heavy Duty Open Burner Top Range

Item: _____
 Quantity: _____
 Project: _____
 Approval: _____
 Date: _____

Master Series Heavy Duty Open Burner Top Range

Models:

- M44R M44S M44T

Range with Four Open Burners



Model M44R

Standard Features:

- Stainless steel front; black powder coat epoxy sides
- 6" (152mm) chrome steel adj. legs
- 7-1/2" (191mm) stainless steel front rail
- Four 35,000 BTU, (10.25 kW), (natural gas) or 32,000 BTU (9.37kW) (propane), two piece Starfire burners with removable heads
- Removable ring grate bowl over each burner
- Cast iron top grates
- One-piece Stainless Steel drip tray
- Piezo spark ignition for oven
- Fully porcelainized oven interior
- 40,000 BTU, (11.72 kW) natural gas or 35,000 BTU (10.25kW) propane, cast iron oven burner
- Storage base interior of aluminized steel

Optional Features:

- Stainless steel left, right or both sides or main back
- Stainless steel common front rail up to 68" (1728mm) wide (two or more units in a battery)

- Stainless steel oven interior
- Convection oven base, add C to Model No., e.g. M44RC
- Additional oven rack
- Rear gas connection, 3/4" or 1" NPT
- Gas regulator 3/4" or 1-1/4"
- Gas shut off valve; 3/4", 1" or 1-1/4" NPT
- Gas flex hose & quick disconnect (3/4", 1" or 1-1/4" NPT x 5') w/ restraining device, please specify
- End caps and cover, NC specify
- 4 Swivel casters w/front brakes
- 4 Polyurethane non-marking swivel casters w/front brakes
- 6" (152mm) stainless steel adj. legs
- Dais base (not for use with "RC" oven)
- Storage base shelf of aluminized or stainless steel
- Stainless steel tubular high shelf, single or double deck
- Stainless steel backguard: 10" (354mm), 17" (432mm) or 33" (838mm)
- 230 volt, 50 cycle components, RC motor (export)
- Celsius dial for oven thermostat (NC)

Specifications:

Heavy-duty gas range with oven, Model M44R. Four 35,000 BTU, (10.25 kW), two-piece Starfire burners. Heavy-duty cast iron top grates and ring grates. 34" (864mm) wide x 38" (965mm) deep, including 7-1/2" (191mm) deep stainless steel front rail. Porcelain enamel oven interior with 40,000 BTU (11.72 kW) cast iron oven burner. Stainless steel front with black powder coat epoxy sides. 180,000 BTU total. (52.74 kW). Natural or propane gas. Also available with storage base w/doors, suffix S, and modular top, suffix T.



NOTE: Ranges supplied with casters must be installed with an approved restraining device.

Garland Commercial Industries, LLC
 185 East South Street
 Freeland, PA 18224
 Phone: (570) 636-1000
 Fax: (570) 636-3903

Garland Commercial Ranges Ltd
 1177 Kamato Road,
 Mississauga, Ontario
 L4W 1X4 CANADA
 Phone: 905-624-0260
 Fax: 905-624-5669



Product	Width: In(mm)	Depth: In(mm)	Height: In(mm) (w/ NSF Legs)	Height: In(mm) (w/o NSF Legs)	Oven/Storage Base Interior: in(mm)		
					Width	Depth	Height
M44R	34(864)	38(965)	36-3/8(924)	30-3/8(772)	26-1/4(667)	29(737)**	13-1/2(343)
M44S	34(864)	38(965)	36-3/8(924)	30-3/8(772)	26(665)	30-1/2(773)	20-1/2(519)
M44T	34(864)	38(965)	36-3/8(924) w/stand	9-1/2 (241) w/o stand*	N/A	N/A	N/A

*Modular top has 1-1/2" seating flanges **RC oven is 25" (635mm) deep

INPUT-BTU/hr	M44R & M44RC		M44S & M44T	
	Natural	Propane	Natural	Propane
Top Section	140,000 (41.02kW)	128,000 (37.48kW)	140,000 (41.02kW)	128,000 (37.48kW)
Oven	40,000 (11.72kW)	35,000(10.25kW)	N/A	N/A
TOTAL	180,000(52.74kW)	163,000 (47.73kW)	140,000(41.02kW)	128,000 (37.48kW)

RC=Range w/Convection Oven R=Range w/Oven S=Range w/Storage Base T=Modular Top

INSTALLATION NOTES			Shipping Wt: (Lb/Kg) ²
Combustible Wall Clearances ¹	Entry Clearances	Operating Pressure	
Sides: 14" (356mm) Back: 6" (152mm)	Crated: 39-1/4" (997mm) Uncrated: 34-1/4" (870mm)	Natural: 6" WC (15mbar) Propane: 10" WC (25mbar)	M44R 440/200 M44S 340/1551 M44T 250/114

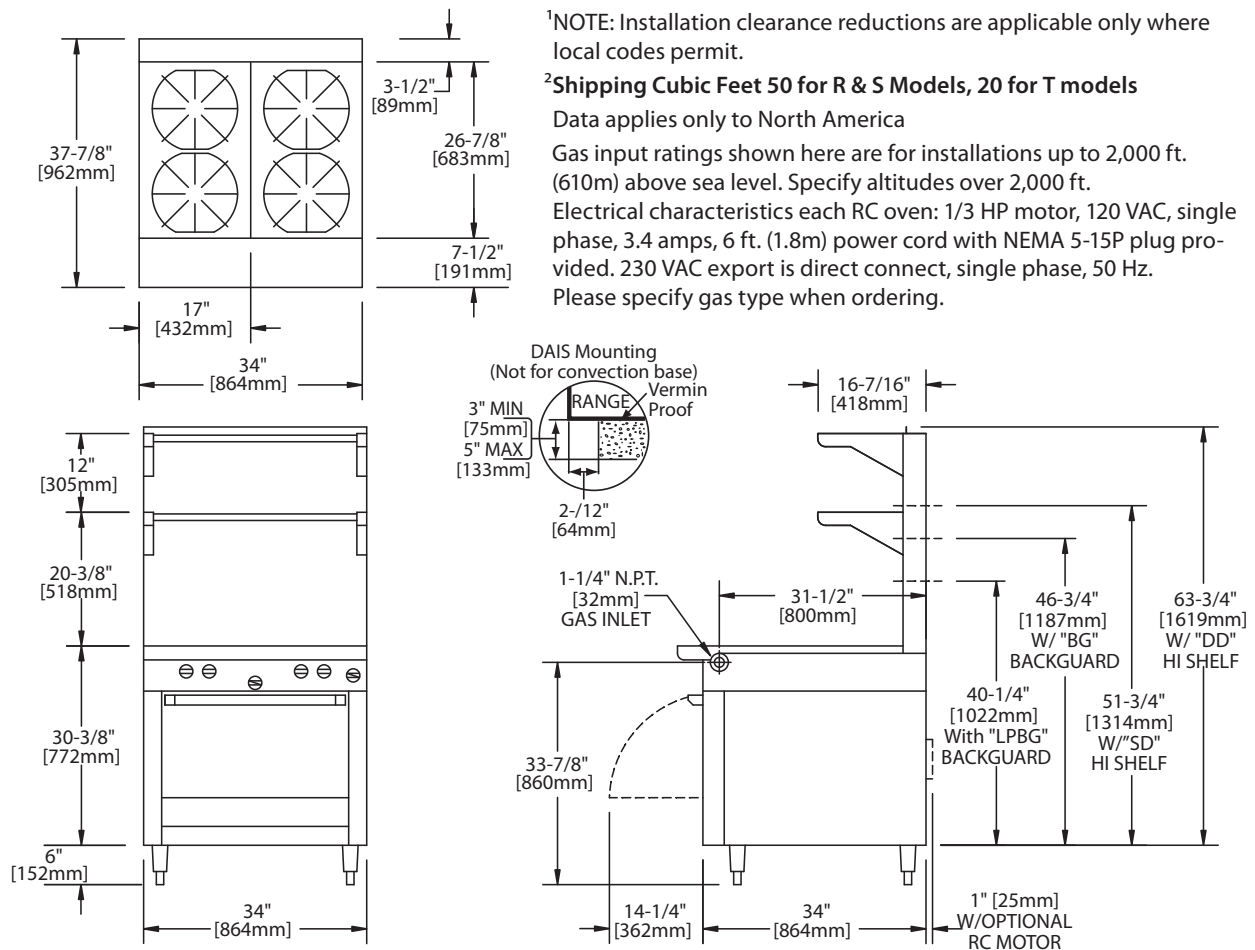

Form# M44 (09/02/09)