



# Master Series Heavy Duty Front-Fired Hot Top Range

Item: \_\_\_\_\_  
 Quantity: \_\_\_\_\_  
 Project: \_\_\_\_\_  
 Approval: \_\_\_\_\_  
 Date: \_\_\_\_\_

Master Series Heavy Duty Front-Fired Hot Top Range

Models:

- M45R       M45S       M45T

Two Front-Fired Hot Top Range



Model M45R

### Standard Features:

- Stainless steel front; black powder coat epoxy sides
- 6" (152mm) chrome steel adj. legs
- 7-1/2" (191mm) stainless steel front rail
- Two 17" (432mm) extra-heavy cast iron top sections, each with 3 individually controlled jet burners rated 45,000 BTU (13.16 kW) natural or 33,000 BTU (9.66 kW) propane total each section
- Removable cast iron ring and lid
- Heavy gauge, aluminized steel radiation baffle system
- 1-piece Stainless Steel drip tray
- Piezo spark ignition for oven
- Fully porcelainized oven interior
- 40,000 BTU (11.72 kW) natural gas, 35,000 BTU (10.25 kW) propane gas, cast iron oven burner
- Storage base interior of aluminized steel w/shelf (suffix S)
- Modular top available (suffix T)

### Optional Features:

- Stainless steel oven interior
- Stainless steel common front rail up to 68" (1728mm) wide (two or more units in a battery)

- Stainless steel left, right or both sides or main back
- Convection oven base, add C to Model No., e.g., M45RC
- Additional oven racks
- Rear gas connection, 3/4" or 1-1/4" NPT; exterior mount, left or right, add 5-1/4"(133mm) to range width
- Gas regulator 3/4" or 1-1/4"
- Gas shut off valve; 3/4", 1" or 1-1/4" NPT
- Gas flex hose & quick disconnect (3/4", 1" or 1-1/4" NPT x 5') w/ restraining device, please specify
- End caps and cover, (NC, specify)
- 4-Swivel casters w/front brakes
- 4-Polyurethane non-marking swivel casters w/front brakes
- 6" (152mm) stainless steel adj. legs
- Dais base (not for use with "RC" oven)
- Storage base shelf of stainless steel
- Stainless steel tubular high shelf, single or double deck
- Stainless steel backguard: 10" (354mm), 17" (432mm) or 33" (838mm)
- 230 volt, 50 cycle components, RC motor (export)
- Celsius dial for oven thermostat (NC)

### Specifications:

Heavy-duty gas range with oven, Model M45R. Two (2) 17" (432mm) front fired spectro-heat hot tops, total 90,000 BTU (26.37 kW) natural gas. 34" (864mm) wide x 38" (965mm) deep, including 7-1/2" (191mm) deep stainless steel front rail. Porcelain enamel oven with 40,000 BTU (11.72 kW), natural gas, cast iron burner. Stainless steel front with black powder coat epoxy sides. 130,000 BTU (38.09 kW) total. Natural or propane gas available Also available with storage base w/ doors, suffix S, and modular top, suffix T.



NOTE: Ranges supplied with casters must be installed with an approved restraining device.

Garland Commercial Industries, LLC  
 185 East South Street  
 Freeland, PA 18224  
 Phone: (570) 636-1000  
 Fax: (570) 636-3903

Garland Commercial Ranges Ltd  
 1177 Kamato Road,  
 Mississauga, Ontario  
 L4W 1X4 CANADA  
 Phone: 905-624-0260  
 Fax: 905-624-5669



Product	Width: In(mm)	Depth: In(mm)	Height: In(mm) (w/ NSF Legs)	Height: In(mm) (w/o NSF Legs)	Oven/Storage Base Interior: in(mm)		
					Width	Depth	Height
M45R	34(864)	38(965)	36-3/8(924)	30-3/8(772)	26-1/4(667)	29(737)**	13-1/2(343)
M45S	34(864)	38(965)	36-3/8(924)	36-3/8(924)	26(665)	30-1/2(773)	20-1/2(519)
M45T	34(864)	38(965)	36-3/8(924) w/stand	9-1/2 (241) w/o stand*	N/A	N/A	N/A

\*Modular top has 1-1/2" seating flanges. \*\*RC oven is 25"(635mm) deep.

INPUT-BTU/hr	M45R & M45RC		M45S & M45T	
	Natural	Propane	Natural	Propane
<b>Total Top Section</b>	90,000 (26.37kW)	66,000 (19.33kW)	90,000 (26.37kW)	66,000 (19.33kW)
<b>Oven</b>	40,000 (11.72kW)	35,000 (10.25kW)	N/A	N/A
<b>TOTAL</b>	130,000(38,37kW)	101,000 (29.58kW)	90,000(37.217kW)	66,000(19.33kW)

RC=Range w/Convection Oven R=Range w/Oven S=Range w/Storage Base T=Modular Top

INSTALLATION NOTES			Shipping Wt: (Lb/Kg) <sup>2</sup>	
<b>Combustible Wall Clearances<sup>1</sup></b>	<b>Entry Clearances</b>	<b>Operating Pressure</b>	M45R	510/232
			M45S	410/186
Sides: 14" (356mm) Back: 6" (152mm)	Crated: 39-1/4" (997mm) Uncrated: 34-1/4" (870mm)	Natural: 6" WC (15mbar) Propane: 10" WC (25mbar)	M45T	305/138

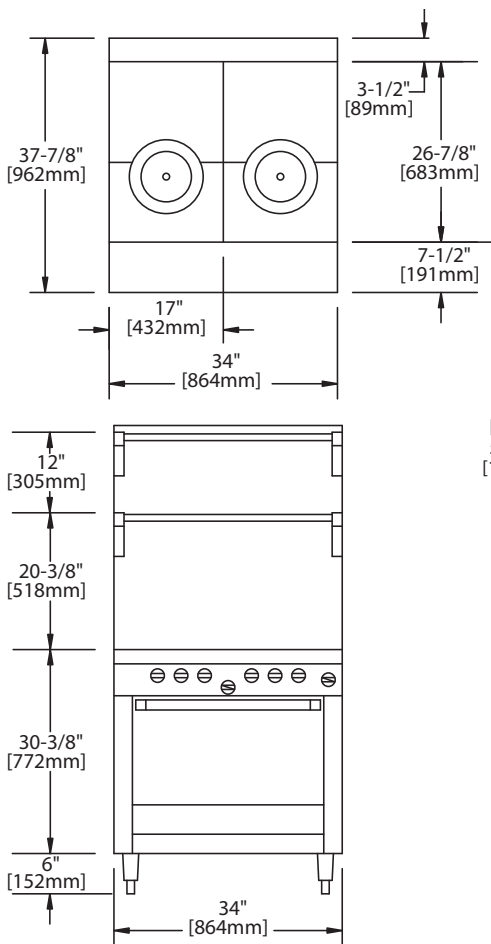

<sup>1</sup>NOTE: Installation clearance reductions are applicable only where local codes permit.  
<sup>2</sup>Shipping Cubic Feet 50 for R & S Models, 20 for T models  
 Data applies only to North America  
 Gas input ratings shown here are for installations up to 2,000 ft. (610m) above sea level. Specify altitudes over 2,000 ft.  
 Electrical characteristics each RC oven: 1/3 HP motor, 120 VAC, single phase, 3.4 amps, 6 ft. (1.8m) power cord with NEMA 5-15P plug provided. 230 VAC export is direct connect, single phase, 50 Hz.  
 Please specify gas type when ordering.

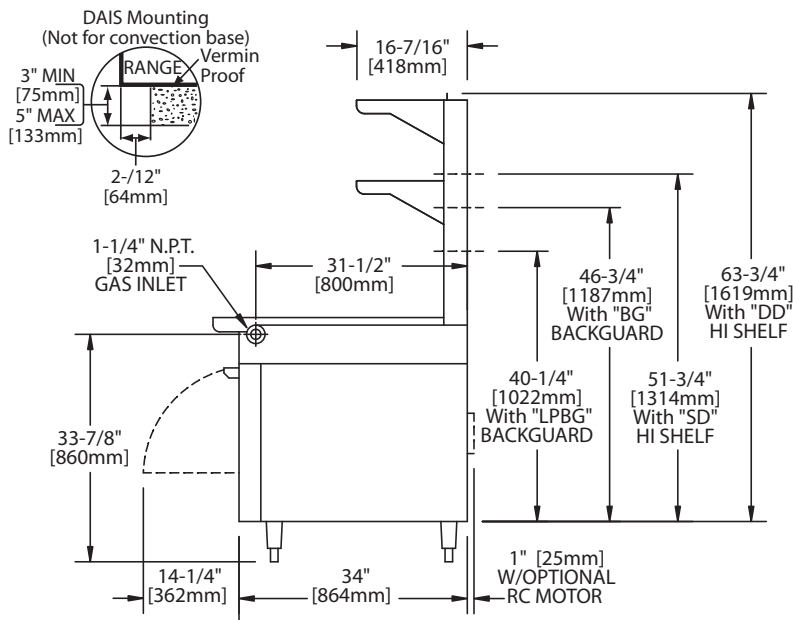

Form# M45 (09/02/09)