



Project _____
 Item # _____
 Quantity _____

SPECTRUM

Commercial Microwave with Dial Controls

Models: EMW-1000SD

The Spectrum Dial Control Microwave is the ideal choice for convenience and speed when heating soups, sandwiches or pre-packed meals. At a powerful 1000W, with a unique motor-driven bottom antenna for efficient energy distribution, this commercial microwave provides consistent results with frequent, repeated use, essential for quick-serve restaurants, concession stands, prep stations and more. Features include a spacious 0.9 cu. ft. capacity, and customizable power levels and cook timer up to 60 minutes. This attractive, fully stainless steel interior and exterior unit is durable and easy-to-clean.



Standard Features

- ◆ 1,000 watts of cooking power for quick heating
- ◆ Motor-driven bottom antenna for efficient energy distribution and consistent results
- ◆ Engineered for commercial kitchen use
- ◆ Stainless steel interior with bottom ceramic plate
- ◆ Ample 0.9 cubic feet (25 L) oven capacity
- ◆ Accommodates 12" (30.5 cm) diameter platter
- ◆ Adjustable power levels and cook timer, up to 60 minutes
- ◆ Backlit LED display
- ◆ Interior oven light
- ◆ One year parts and labor warranty



Options & Accessories

PTW-7K	Tortilla Warmer
PH-8N	Neoprene Pot Holder
PFS-1	Face Shield
PPCR-Series	Plate Covers

For California Customers
 ⚠️ **WARNING:** Cancer and Reproductive Harm - www.P65Warnings.ca.gov

New Jersey: 888-946-2682
Florida: 786-536-4656
California: 888-946-2652

equipsales@wincous.com

www.wincous.com

• Lodi, New Jersey
 • Miami, Florida
 • La Mirada, California



Commercial Microwave with Dial Controls

Models: EMW-1000SD

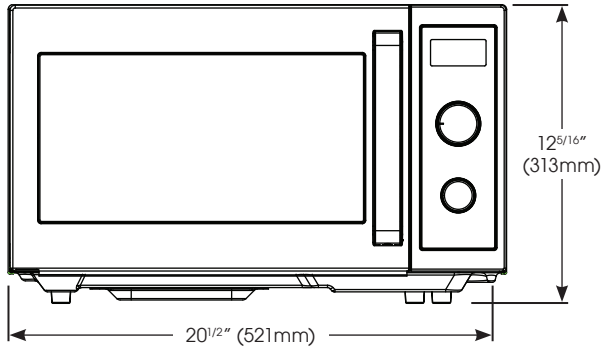

FRONT VIEW

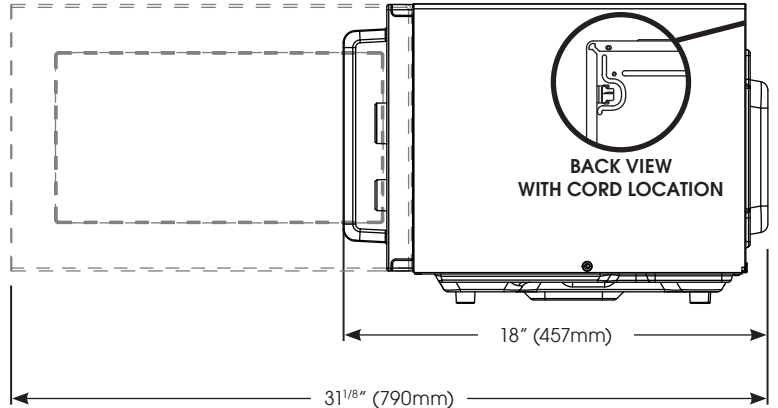

SIDE VIEW WITH DOOR OPEN

MODEL	DESCRIPTION	OVERALL DIMENSIONS			VOLTS	HZ/PH	WATTS	AMPS	PLUG	SHIP WEIGHT
		LENGTH	DEPTH	HEIGHT						
EMW-1000SD	Commercial Microwave with Dial Controls	20-1/2" (521mm)	18" (457mm)	12-5/16" (313mm)	120	60	1,000	12	NEMA 5-15P	44.1 lbs (20 kgs)

*Note: Minimum clearance Top 12"(300mm), Sides 4"(100mm), Back 4"(100mm)

Cord Location

On back top right rear

Plug Configuration

NEMA 5-15P

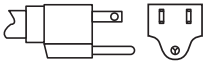

Product Specs

Commercial Microwave with Dial Controls

The Dial Control Microwave model EMW-1000SD as manufactured by Winco®, Lodi, NJ 07644.

Dial Control Microwave model EMW-1000SD shall be rated at 1000 Watts with NEMA 5-15P plug. Microwave shall have adjustable power levels and cook timer, up to 60 minutes, motor-driven bottom antenna for efficient energy distribution and consistent results, backlit LED display, and interior oven light. Units shall be constructed of stainless steel interior with bottom ceramic plate. Cavity shall have a capacity of 0.9 cubic ft (25L) and accommodates a 12" (305mm) platter. cULus and ETL Sanitation listed.

Warranty consists of one year parts and labor.



New Jersey: 888-946-2682
 Florida: 786-536-4656
 California: 888-946-2652



equipsales@wincous.com



www.wincous.com



• Lodi, New Jersey
 • Miami, Florida
 • La Mirada, California