

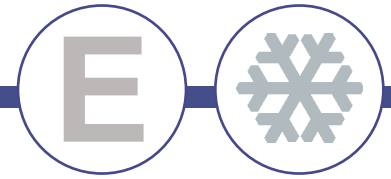

Series "A"



Sandwich and Salad Units with Stainless Steel Interior



Model	Size
S29-SI-HC	29" Unit
S48-SI-HC	48" Unit
S61-SI-HC	61" Unit
S72-SI-HC	72" Unit

STANDARD FEATURES

- Solid state thermostat with digital display
- 1/6 size Lexan pans included
- Full-length poly-vinyl cutting board included
- Stainless steel front, sides AND interior
- Self closing doors remain open past 90°
- Environmentally friendly R290
- EZ slide out condenser
- Whisper quiet
- Solid construction
- Full length integrated door handle
- Casters with two front brakes
- Cool air intake
- Clearance 2" sides, 2" Rear

*Not suitable for installation in a non-commercial or residential applications.

Items	Description	Items	Description
Front, top & sides	Stainless steel	Temperature control	Solid state thermostat/Digital display
Doors	Stainless steel inside and outside	Approvals	ETL Listed
External back	Aluminum	Refrigerating system	Capillary tube
Cabinet interior	Stainless steel	Refrigerant	R290
Interior floor	Stainless steel	Temperature range	34-38F
Insulation	Polyurethane (CFC free)	Evaporator	Powder coated aluminum/copper
Shelves	Heavy duty, PVC coating	Condensing unit	Rear mounted
Cutting board	Vinyl (included)		

REFRIGERATION

CONFORMS TO NSF/ANSI STD 7

Customer Service (704) 900-2068 - www.entree.biz - greatfoods@entree.biz





DETAILS AND DIMENSIONS

S29-SI-HC

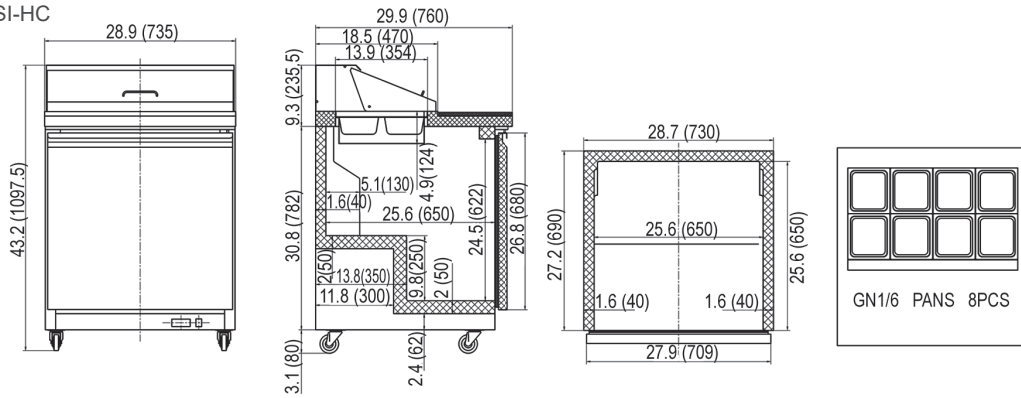

S48-SI-HC

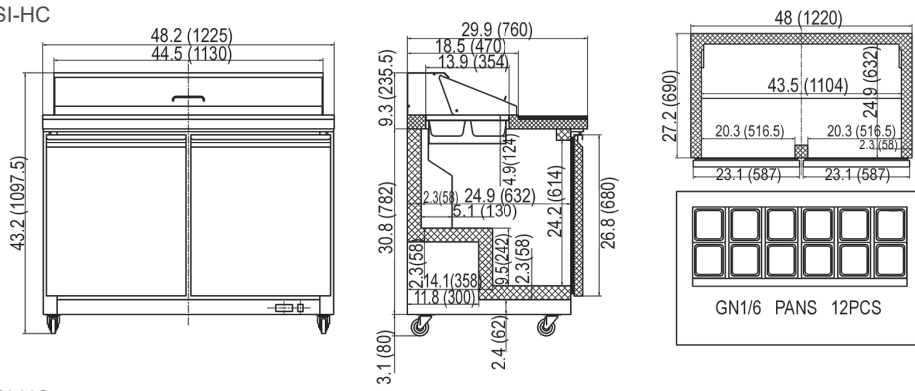

S61-SI-HC

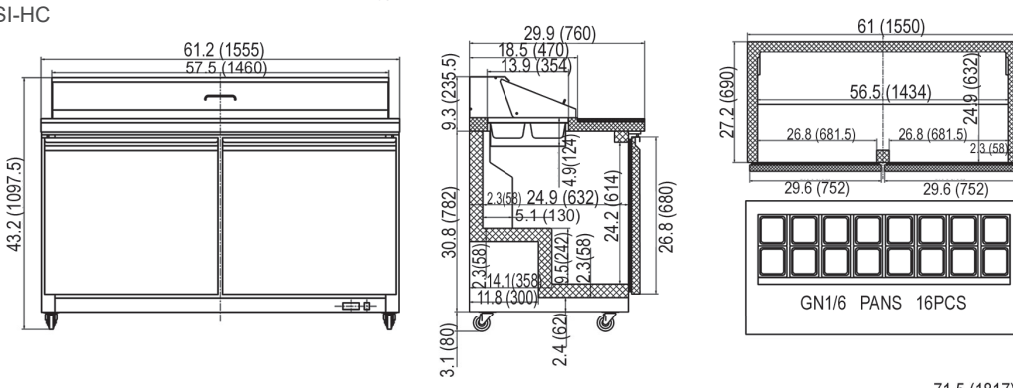

S72-SI-HC

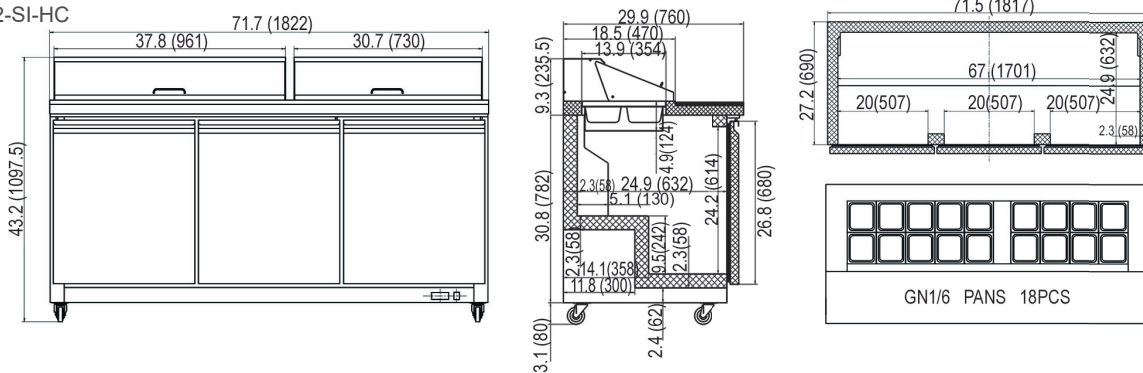

Model	Doors	Shelves	Pans	Cabinet Dim (inches)			HP	Voltage	Amps	NEMA Plug	Cord Length	Crated Weight
				L	D	H						
S29-SI-HC	1	1	8 (1/6)	28.9	29.9	43.2	1/3	115/60/1	3	5-15P	10	276
S48-SI-HC	2	2	12 (1/6)	48.2	29.9	43.2	1/2	115/60/1	4.3	5-15P	10	313
S61-SI-HC	2	2	16 (1/6)	61.2	29.9	43.2	1/2	115/60/1	4.3	5-15P	10	362
S72-SI-HC	3	6	18 (1/6)	71.7	29.9	43.2	1/2	115/60/1	4.3	5-15P	10	408