



Founded in 1946

Project: \_\_\_\_\_

Items: \_\_\_\_\_

Quantity: \_\_\_\_\_

Approval: \_\_\_\_\_

Date: \_\_\_\_\_

HEATER PROOFERS

## Standard / Economy Heater Proofers

This unit is designed to promote efficiency and reduce redundancy in operations by combining the function of two equipment into one and leveraging the advent of technology.

### Features:

- Heavy duty aluminum construction
- Forced air design
- Dual proof/heat digital thermostatic control with temperature sensor and circuit breaker. Available with read-out LED digital or analog display.
- Proof mode: 95% RH at 110°F
- Heat mode: max temp 180°F
- Corner bumpers
- Cabinet doors have aluminum frame and lexan window
- Removable analog or digital drawer
- Can hold (35) 18" x 26" pans
- Electrical specifications: 120V - 60 HZ, plugs into standard 110V outlet, NEMA 5/15P

### Benefits:

- Pans can be loaded from bottom
- Clear lexan door allows for greater visibility of food items
- Forced air design provides even heat distribution
- Less time and effort spent closely monitoring temperature and moisture within the unit
- Easily attain accurate and precise temperature and level
- Food quality, texture and freshness are well-maintained
- Overcurrent protection to the entire equipment
- Removable digital or analog drawer allows for easy and efficient cleaning



**Standard**  
NHPL-1836C-DGT



**Economy**  
NHPL-1836-ECOC





Founded in 1946

# Standard / Economy Heater Proofers



Digital Drawer

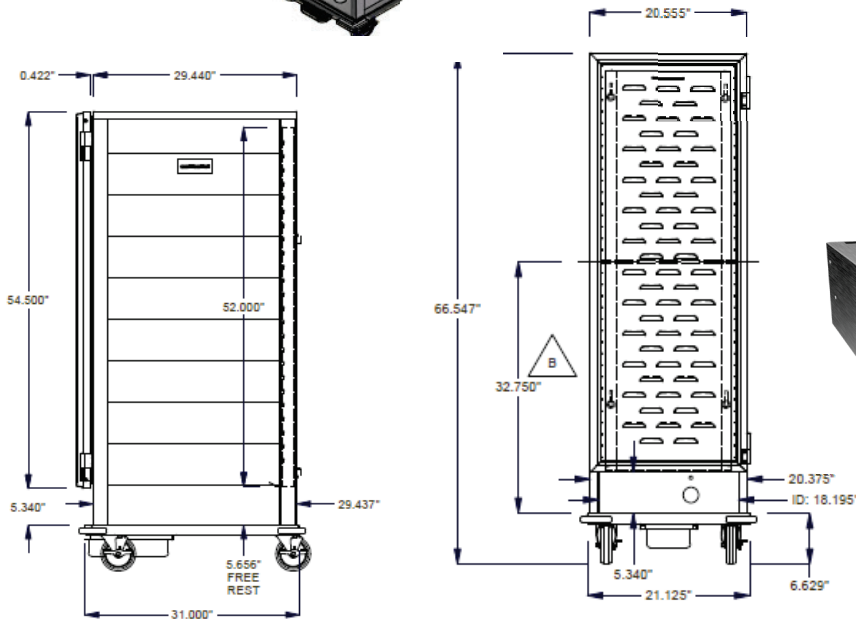

Analog Drawer

Model Number	Order#	Overall Dimensions						Approx. Ship Wt	
		Width		Length		Height		(lb)	(kg)
		(in)	(mm)	(in)	(mm)	(in)	(mm)		
NHPL-1836C-DGT	1078985	21	533	32.75	832	66.5	1689	136	60
NHPL-1836-ECOC	684668	21	533	32.75	832	66.5	1689	136	60

**Caster Information:**

- Swivel plate caster with 5" polyurethane wheel 738A (128784)
- Swivel plate caster with 5" polyurethane wheel and brake 738ABK (204185)
- 5" Polyurethane wheel 7112 (122180)

**Freight Class: 175**



In line with our policy to continually improve our products, Winholt reserves the right to change materials and specifications without notice.